



ProtoCessor FPC-ED2 Start-up Guide

For Interfacing Leonard Valve Products: Valve
To Building Automation Systems:
BACnet MS/TP, BACnet/IP, Modbus TCP/IP, Modbus RTU,
Metasys N2 and EtherNet/IP

APPLICABILITY & EFFECTIVITY

Explains ProtoCessor hardware and how to install it.

The instructions are effective for the above as of November 2017.

Technical Support

Thank you for purchasing the ProtoCessor for Leonard Valve.

Please call Leonard Valve for Technical support of the ProtoCessor product.

Sierra Monitor Corporation does not provide direct support. If Leonard Valve needs to escalate the concern, they will contact Sierra Monitor Corporation for assistance.

Support Contact Information:

Leonard Valve
1360 Elmwood Avenue
Cranston, RI 02910

Customer Service:

(401) 461-1200
(800) 222-1208

Website: leonardvalve.com

Email: info@leonardvalve.com

Quick Start Guide

1. Record the information about the unit. (**Section 3.1**)
2. Set the COM settings for the device connected to ProtoCessor. (**Section 3.3**)
3. **Connect ProtoCessor FPC-ED2's** 3 pin RS-485 port to the Field Protocol cabling. (**Section 4.2**)
4. Use a browser to access the ProtoCessor's embedded tool, which is referred to in this manual as the Web Configurator, to select the device that will be attached to ProtoCessor. Once the device is selected, the ProtoCessor Automatically builds and loads the Configuration. (**Section 5**)
5. BACnet/IP, Modbus TCP/IP or EtherNet/IP: Use a browser to access the ProtoCessor Web Configurator to change the IP Address. No changes to the configuration are necessary. (**Section 5.5**)

TABLE OF CONTENTS

- 1 Certifications 6**
 - 1.1 BTL Mark – BACnet® Testing Laboratory 6
- 2 Introduction 7**
 - 2.1 ProtoCessor Gateway 7
- 3 Setup for ProtoCessor 8**
 - 3.1 Record Identification Data 8
 - 3.2 Point Count Capacity and Registers per Device 8
 - 3.3 Configuring Device Communications 8
 - 3.3.1 Input COM Settings on the Device Connected to the ProtoCessor 8
- 4 Interfacing ProtoCessor to Devices 9**
 - 4.1 ProtoCessor FPC-ED2 Showing Connection Ports 9
 - 4.2 BACnet MS/TP, Modbus RTU, Metasys N2: Wiring Field Port to RS-485 Network. 10
- 5 Use ProtoCessor Web Configurator to Setup the Gateway 11**
 - 5.1 Connect the PC to ProtoCessor via the Ethernet Port 11
 - 5.2 Connecting to ProtoCessor Web Configurator 12
 - 5.3 Select Field Protocol 14
 - 5.4 Devices Connected to ProtoCessor 15
 - 5.5 Ethernet Network: Setting IP Address for Field Network 17
- 6 How to Start the Installation Over: Clearing Profiles 19**
- 7 BACnet Explorer NG 20**
- Appendix A. Troubleshooting 21**
 - Appendix A.1. Lost or Incorrect IP Address 21
 - Appendix A.2. Viewing Diagnostic Information 22
 - Appendix A.3. Check Wiring and Settings 23
 - Appendix A.4. LED Diagnostics for Communications Between ProtoCessor and Device 24
 - Appendix A.5. Take Diagnostic Capture with the FieldServer Toolbox 25
 - Appendix A.6. Update Firmware 28
 - Appendix A.7. BACnet: Setting Network_Number for more than one ProtoCessor on Subnet 28
 - Appendix A.8. Securing ProtoCessor with Passwords 29
- Appendix B. Vendor Information – Leonard Valve 30**
 - Appendix B.1. Valve Modbus RTU Mappings to BACnet, Metasys N2 and EtherNet/IP 30
- Appendix C. Reference 31**
 - Appendix C.1. Specifications 31
 - Appendix C.1.1. Compliance with UL Regulations 31
- Appendix D. Limited 2 Year Warranty 32**

LIST OF FIGURES

Figure 1: ProtoCessor Part Numbers..... 8

Figure 2: Supported Point Count Capacity 8

Figure 3: Registers per Device 8

Figure 4: COM Settings..... 8

Figure 5: ProtoCessor FPC-ED2 9

Figure 6: Connection from ProtoCessor to RS-485 Field Network..... 10

Figure 7: RS-485 BMS Network EOL Switch..... 10

Figure 8: Web App Splash Page..... 12

Figure 9: Login Window 12

Figure 10: Web App Landing Page..... 13

Figure 11: Configuration Tab 13

Figure 12: Web Configurator Showing Protocol Selector Parameter 14

Figure 13: Web Configurator Showing no Active Profiles 15

Figure 14: Web Configurator Showing Active Profile Additions..... 16

Figure 15: Web Configurator Screen 17

Figure 16: Changing IP Address via FS-GUI 18

Figure 17: BACnet Explorer NG on a BACnet Network..... 20

Figure 18: Ethernet Port Location 21

Figure 19: Error Messages Screen 22

Figure 20: Diagnostic LEDs 24

Figure 21: Ethernet Port Location 25

Figure 22: Web Configurator – Network Number Field..... 28

Figure 23: FS-GUI Passwords Page..... 29

Figure 24: Password Recovery Page 29

Figure 25: Specifications 31

1 CERTIFICATIONS

1.1 BTL Mark – BACnet^{®1} Testing Laboratory



BACnet is a registered trademark of ASHRAE. ASHRAE does not endorse, sponsor or test products for compliance with ASHRAE standards. Compliance of listed products to requirements of ASHRAE Standard 119 is the responsibility of the BACnet International. BTL is a registered trademark of the BACnet International.

The BTL Mark on ProtoCessor is a symbol that indicates that a product has passed a series of rigorous tests conducted by an independent laboratory which verifies that the product correctly implements the BACnet features claimed in the listing. The mark is a symbol of a high-quality BACnet product.

Go to www.BACnetInternational.net for more information about the BACnet Testing Laboratory. Click [here](#) for the BACnet PIC Statement.

¹ BACnet is a registered trademark of ASHRAE.

2 INTRODUCTION

2.1 ProtoCessor Gateway

The ProtoCessor is an embedded module that is designed into Leonard Valve’s product (hereafter called “device”) and is preconfigured to support BACnet MS/TP, BACnet/IP, Metasys^{®2} N2 by JCI, Modbus TCP/IP, Modbus RTU or EtherNet/IP.

It is not necessary to download any configuration files to support the required applications. The ProtoCessor is pre-loaded with all the tested Profiles/Configurations for the device to support the desired protocols.

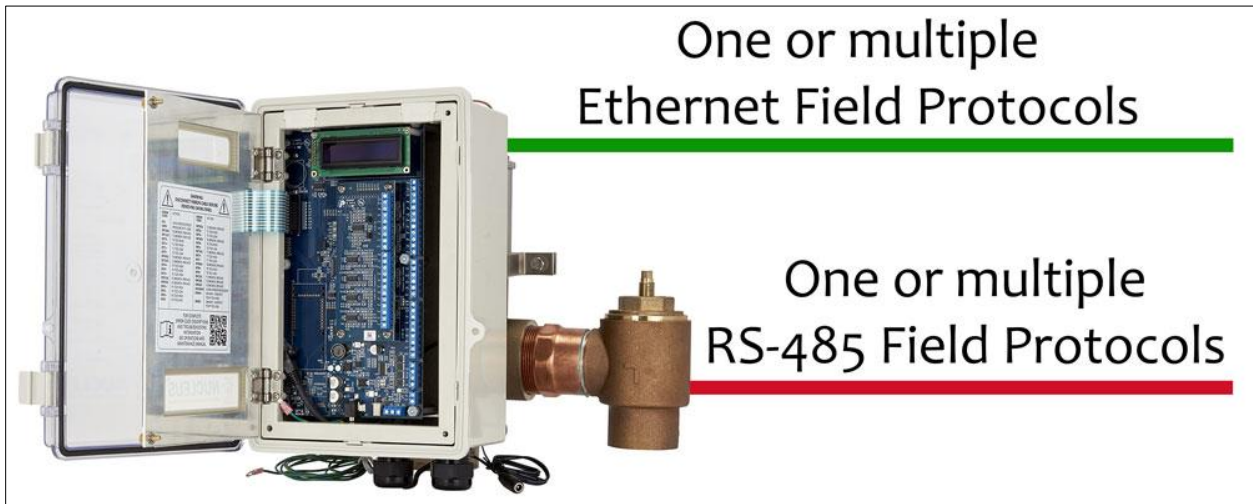

² Metasys is a registered trademark of Johnson Controls Inc.

3 SETUP FOR PROTOCESSOR

3.1 Record Identification Data

Each ProtoCessor has a unique part number located on the side or the back of the unit. This number should be recorded, as it may be required for technical support. The numbers are as follows:

Model	Part Number
ProtoCessor FPC-ED2	FPC-ED2-1145

Figure 1: ProtoCessor Part Numbers

- FPC-ED2 units have the following 2 ports: RS-485 + Ethernet

3.2 Point Count Capacity and Registers per Device

The total number of Registers presented by the device attached to the ProtoCessor cannot exceed:

Part number	Total Registers
FPC-ED2-1145	1,500

Figure 2: Supported Point Count Capacity

Devices	Registers Per Device
Valve	41

Figure 3: Registers per Device

3.3 Configuring Device Communications

3.3.1 Input COM Settings on the Device Connected to the ProtoCessor

- The connected serial device **MUST** have the same Baud Rate, Data Bits, Stop Bits, and Parity settings as the ProtoCessor.
- Figure 4 specifies the device serial port settings required to communicate with the ProtoCessor.

Port Setting	Device
Protocol	PSP
Baud Rate	9600
Parity	None
Data Bits	8
Stop Bits	1

Figure 4: COM Settings

4 INTERFACING PROTOCESSOR TO DEVICES

4.1 ProtoCessor FPC-ED2 Showing Connection Ports

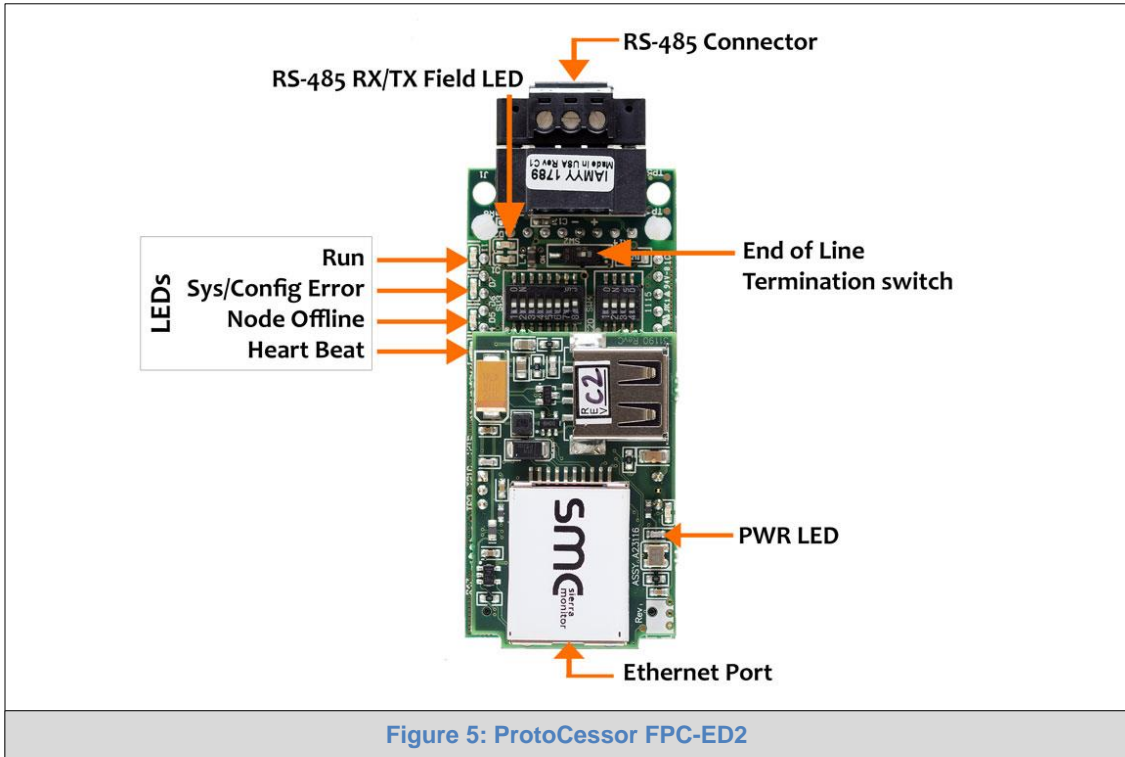
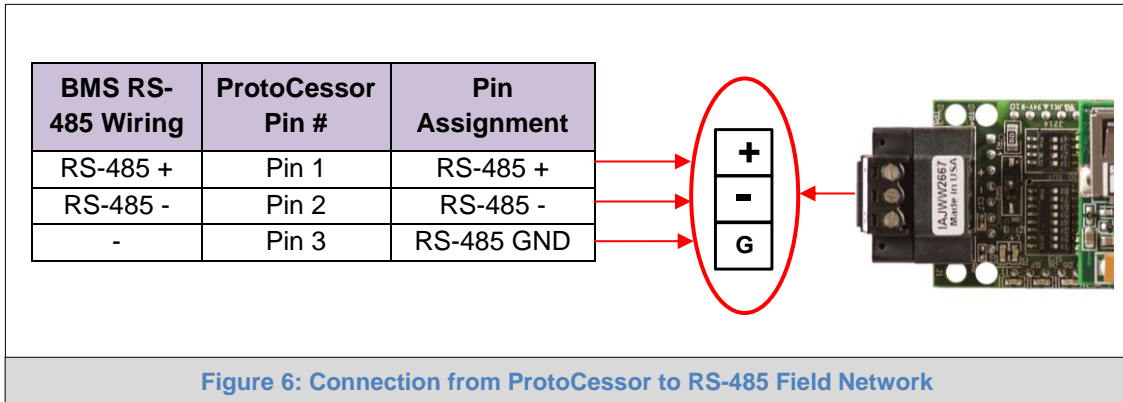

Figure 5: ProtoCessor FPC-ED2

4.2 BACnet MS/TP, Modbus RTU, Metasys N2: Wiring Field Port to RS-485 Network

- Connect the BACnet MS/TP, Modbus RTU or Metasys N2 RS-485 network wires to the 3-pin RS-485 connector on ProtoCessor ED2 as shown below in [Figure 6](#).
 - Use standard grounding principles for RS-485 GND
- See [Section 5.5](#) for information on connecting to BACnet/IP and Modbus TCP/IP network.



- If the ProtoCessor is the last device on the BACnet MS/TP, Modbus RTU or Metasys N2 trunk, then the End-Of-Line Termination Switch needs to be enabled ([Figure 7](#)).
 - The default setting from the factory is OFF (switch position = right side)
 - To enable the EOL Termination, turn the EOL switch ON (switch position = left side)

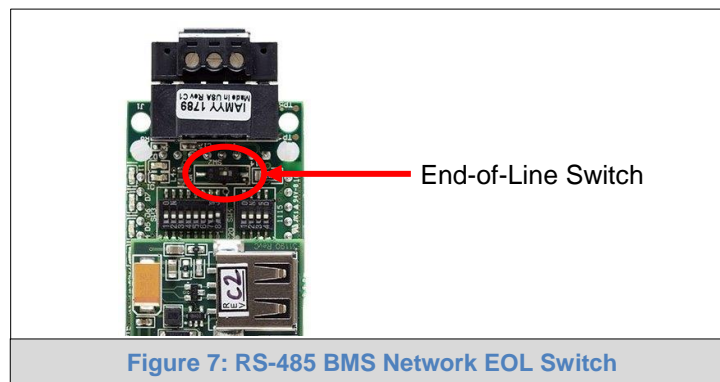





5 USE PROTOCESSOR WEB CONFIGURATOR TO SETUP THE GATEWAY

5.1 Connect the PC to ProtoCessor via the Ethernet Port

- Connect a CAT5 Ethernet cable (Straight through or Cross-Over) between the local PC and ProtoCessor.
- The Default IP Address of ProtoCessor is **192.168.1.24**, Subnet Mask is **255.255.255.0**. If the PC and ProtoCessor are on different IP Networks, assign a static IP Address to the PC on the 192.168.1.xxx network.

For Windows 10:

Right click on  >  Control Panel >  Network and Internet
 >  Network and Sharing Center > [Change adapter settings](#)

Right-click on Local Area Connection > Properties

Highlight [Internet Protocol Version 4 \(TCP/IPv4\)](#) > [Properties](#)

Use the following IP Address:

Use the following IP address:

IP address:	192 . 168 . 1 . 11
Subnet mask:	255 . 255 . 255 . 0
Default gateway:	. . .

Click [OK](#) twice.

5.2 Connecting to ProtoCessor Web Configurator

After setting a local PC on the same subnet as the ProtoCessor (**Section 5.1**), open a web browser on the PC and enter the IP Address of the ProtoCessor; the default address is 192.168.1.24.

NOTE: If the IP Address of the ProtoCessor has been changed by previous configuration, the assigned IP Address can be discovered using the FS Toolbox utility. See **Appendix A.1** for instructions.

- Once at the Web App splash page, click the Login button.

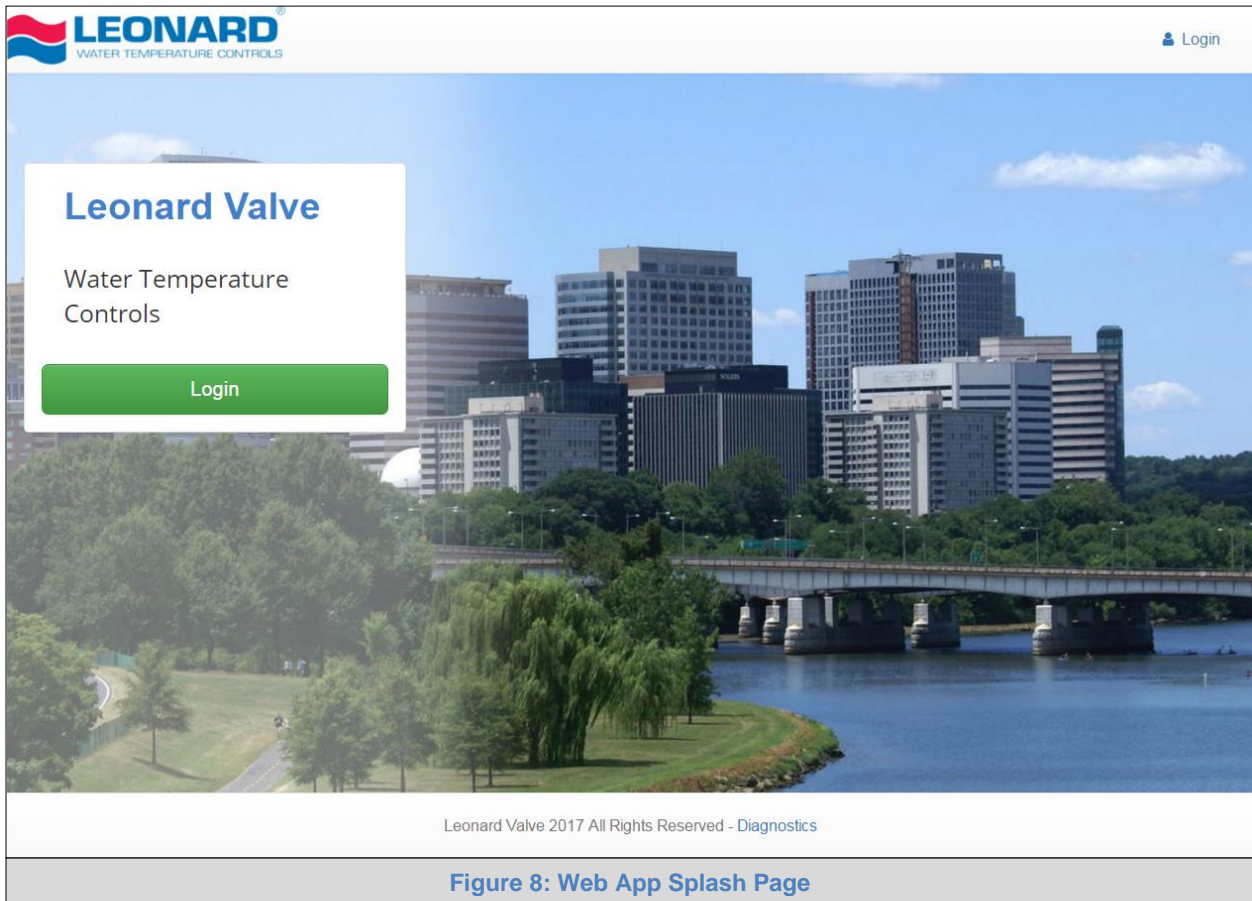

Figure 8: Web App Splash Page

- Enter the previously set up or default username and password.

NOTE: The default username is “admin”. The default password is “admin”.

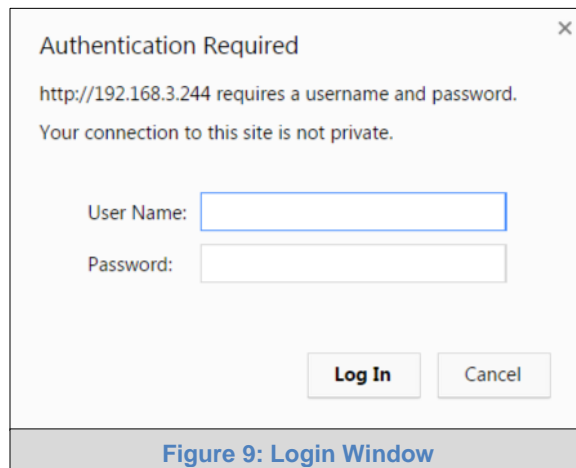

Figure 9: Login Window

- From the Web App landing page (**Figure 10**), click the Configure tab.

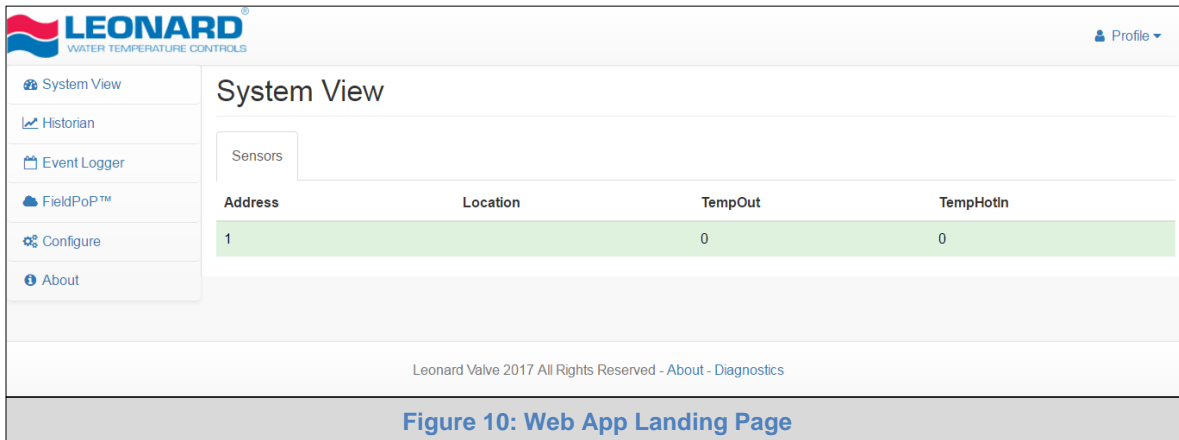

Figure 10: Web App Landing Page

- Then click the Profiles Configuration button to go to the Web Configurator page.

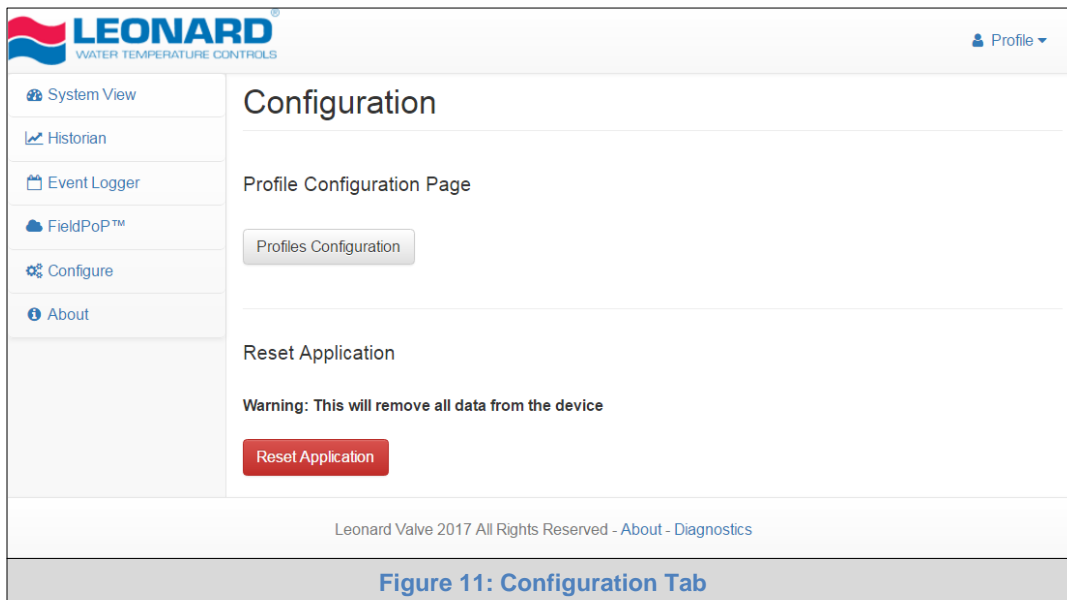



Figure 11: Configuration Tab

NOTE: The FieldPoP™ tab  (see **Figure 11**) allows users to connect to the SMC Cloud, Sierra Monitor’s device cloud solution for IIoT. The SMC Cloud enables secure remote connection to field devices through a FieldServer and its local applications for configuration, management, maintenance. For more information about the SMC Cloud, refer to the [SMC Cloud Start-up Guide](#).

NOTE: For Web App instructions to the System View, Historian and Event Logger functions, see the [SMC Cloud Start-up Guide](#).

5.3 Select Field Protocol

- On the Web Configurator page, the first configuration parameter is the Protocol Selector.

The screenshot shows the 'Configuration Parameters' section of the web configurator. It features a table with columns for 'Parameter Name', 'Parameter Description', and 'Value'. The 'Protocol Selector' parameter is highlighted, with a value of '4' entered in the input field. Below the table, there are sections for 'Active profiles' and a navigation bar with buttons for 'HELP (?)', 'Network Settings', 'Clear Profiles and Restart', 'System Restart', and 'Diagnostics & Debugging'.

Parameter Name	Parameter Description	Value
protocol_select	Protocol Selector Set to 1 for BACnet IP Set to 2 for BACnet MSTP Set to 3 for Metasys N2 Set to 4 for Modbus TCP/Modbus RTU Set to 5 for Ethernet IP	4 <input type="button" value="Submit"/>
mod_baud_rate	Modbus RTU Baud Rate This sets the Modbus RTU baud rate. (9600/19200/38400/57600)	9600 <input type="button" value="Submit"/>
mod_parity	Modbus RTU Parity This sets the Modbus RTU parity. (None/Even/Odd)	None <input type="button" value="Submit"/>
mod_data_bits	Modbus RTU Data Bits This sets the Modbus RTU data bits. (7 or 8)	8 <input type="button" value="Submit"/>
mod_stop_bits	Modbus RTU Stop Bits This sets the Modbus RTU stop bits. (1 or 2)	1 <input type="button" value="Submit"/>

Active profiles

Nr	Node ID	Current profile	Parameters
<input type="button" value="Add"/>			

Navigation buttons:

Figure 12: Web Configurator Showing Protocol Selector Parameter

- Select the field protocol desired, using the number key under the Parameter Description header, and click the Submit button.
 - A message will appear at the top of the screen stating that the update was completed and to restart the system.
- Click the System Restart button on the bottom of the screen and wait for the system to reset.

5.4 Devices Connected to ProtoCessor

NOTE: If Modbus TCP/IP was selected for the Field/BMS protocol, skip this section. Device profiles are NOT used for Modbus TCP/IP.

- In the Web Configurator, the Active Profiles section is shown on the lower left side of the screen.
- The Active Profiles section lists the currently active device profiles, including previous Web Configurator additions. This list is empty for new installations, or after clearing all configurations. (Figure 13)
- To add an active profile to support a device, click the ADD button under Active Profiles. This will present a drop-down box underneath the Current Profile column that lists all the available profiles.

NOTE: Leave the BACnet Virtual Server Nodes field on the default “No” setting.

The screenshot shows the 'Configuration Parameters' section of the web configurator. It contains a table of parameters with their descriptions and current values. Below the table is the 'Active profiles' section, which is currently empty. At the bottom of the page are navigation buttons for HELP, Network Settings, Clear Profiles and Restart, System Restart, and Diagnostics & Debugging.

Parameter Name	Parameter Description	Value
protocol_select	Protocol Selector Set to 1 for BACnet IP Set to 2 for BACnet MSTP Set to 3 for Metasys N2 Set to 4 for Modbus TCP/Modbus RTU Set to 5 for Ethernet IP	1 <input type="button" value="Submit"/>
network_nr	BACnet Network Number This sets the BACnet network number of the Gateway. (1 - 65535)	50 <input type="button" value="Submit"/>
node_offset	BACnet Node Offset This is used to set the BACnet device instance. The device instance will be sum of the Modbus device address and the node offset. (0 - 4194303)	50000 <input type="button" value="Submit"/>
bac_ip_port	BACnet IP Port This sets the BACnet IP port of the Gateway. The default is 47808. (1 - 65535)	47808 <input type="button" value="Submit"/>
bac_cov_option	BACnet COV This enables or disables COVs for the BACnet connection. Use COV_Enable to enable. Use COV_Disable to disable. (COV_Enable/COV_Disable)	COV_Disable <input type="button" value="Submit"/>
bac_bbmd_option	BACnet BBMD This enables BBMD on the BACnet IP connection. Use BBMD to enable. Use - to disable. The bdt.ini files also needs to be downloaded. (BBMD/-)	- <input type="button" value="Submit"/>
bac_virt_nodes	BACnet Virtual Server Nodes Set to NO if the unit is only converting 1 device to BACnet. Set to YES if the unit is converting multiple devices. (No/Yes)	No <input type="button" value="Submit"/>

Active profiles

Nr	Node ID	Current profile	Parameters
<input type="button" value="Add"/>			

Figure 13: Web Configurator Showing no Active Profiles

- For every device that is added, assign a unique Modbus Node-ID. This specification must match the device’s network settings.
- Once the Profile for the device has been selected from the drop-down list, enter the value of the device’s Node-ID.
- Then press the “Submit” button to add the Profile to the list of devices to be configured.
- Repeat this process until all the devices have been added.
- Completed additions are listed under “Active Profiles” as shown in [Figure 14](#).

The screenshot displays the SMC Web Configurator interface. At the top left is the SMC Sierra Monitor logo. The main section is titled "Configuration Parameters" and contains a table with the following columns: Parameter Name, Parameter Description, and Value. Each row includes a text input field and a "Submit" button.

Parameter Name	Parameter Description	Value
protocol_select	Protocol Selector Set to 1 for BACnet IP Set to 2 for BACnet MSTP Set to 3 for Metasys N2 Set to 4 for Modbus TCP/Modbus RTU Set to 5 for Ethernet IP	1
network_nr	BACnet Network Number This sets the BACnet network number of the Gateway. (1 - 65535)	50
node_offset	BACnet Node Offset This is used to set the BACnet device instance. The device instance will be sum of the Modbus device address and the node offset. (0 - 4194303)	50000
bac_ip_port	BACnet IP Port This sets the BACnet IP port of the Gateway. The default is 47808. (1 - 65535)	47808
bac_cov_option	BACnet COV This enables or disables COVs for the BACnet connection. Use COV_Enable to enable. Use COV_Disable to disable. (COV_Enable/COV_Disable)	COV_Disable
bac_bbmd_option	BACnet BBMD This enables BBMD on the BACnet IP connection. Use BBMD to enable. Use - to disable. The bdt.ini files also needs to be downloaded. (BBMD/-)	-
bac_virt_nodes	BACnet Virtual Server Nodes Set to NO if the unit is only converting 1 device to BACnet. Set to YES if the unit is converting multiple devices. (No/Yes)	No

Below the configuration parameters is the "Active profiles" section, which contains a table with columns: Nr, Node ID, Current profile, and Parameters. It shows one active profile and includes "Add" and "Remove" buttons.

Nr	Node ID	Current profile	Parameters
1	1	BAC_IP_Valve	

At the bottom of the interface are several navigation buttons: HELP (?), Network Settings, Clear Profiles and Restart, System Restart, and Diagnostics & Debugging.

Figure 14: Web Configurator Showing Active Profile Additions

5.5 Ethernet Network: Setting IP Address for Field Network

- After setting a local PC to the same subnet as the ProtoCessor (**Section 5.1**), open a web browser on the PC and enter the IP Address of the ProtoCessor; the default address is 192.168.1.24.
- The Web Configurator is displayed as the landing page. (**Figure 15**)
- **To access the FS-GUI, click on the “Diagnostics & Debugging” button** in the bottom right side of the page.

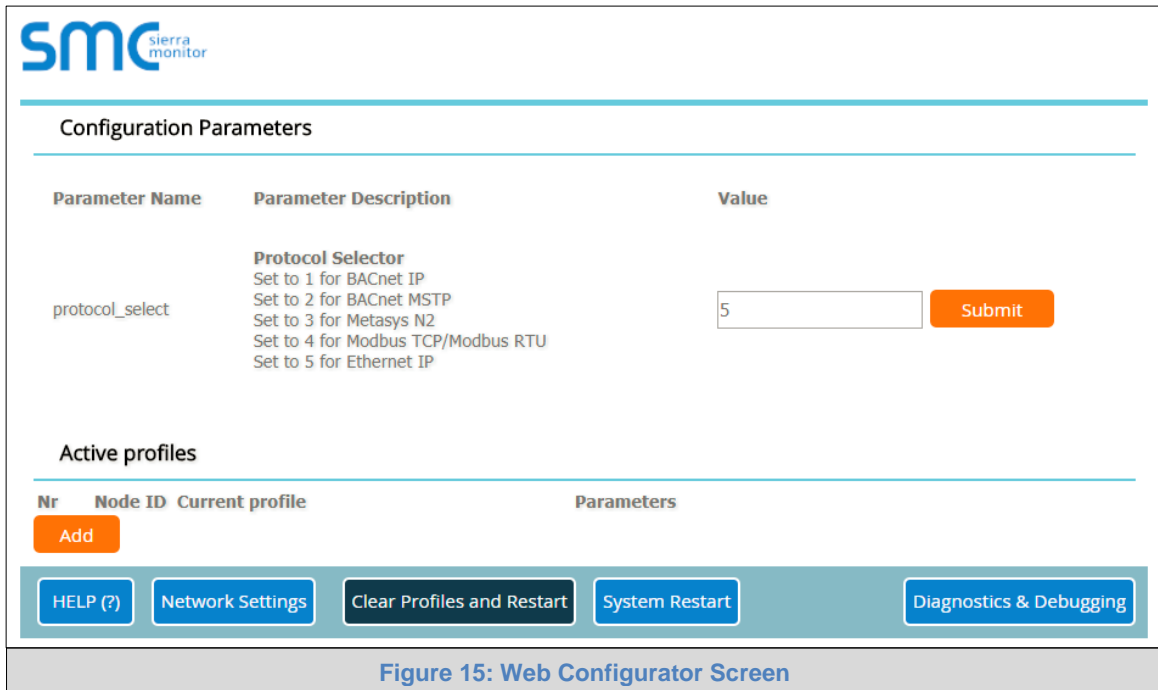

Figure 15: Web Configurator Screen

- From the FS-GUI landing page, click on “Setup” to expand the navigation tree and then select “Network Settings” to access the IP Settings menu. (Figure 16)

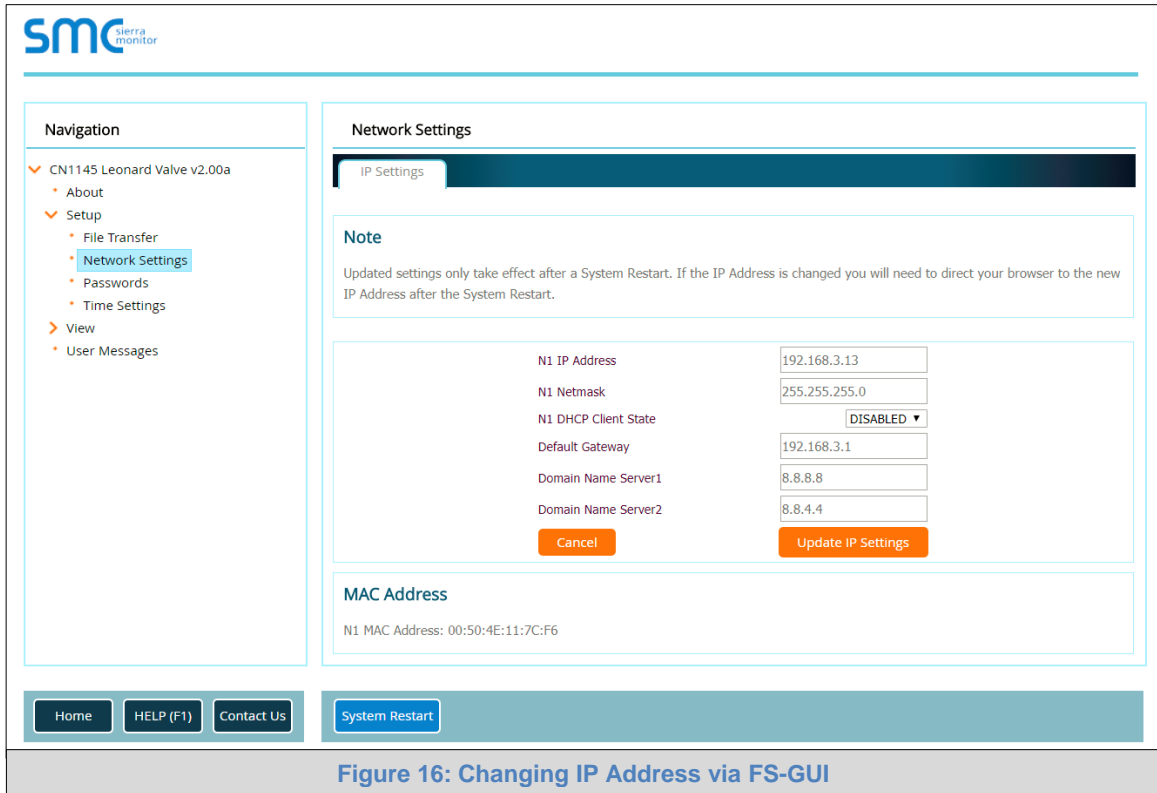

Figure 16: Changing IP Address via FS-GUI

- Modify the IP Address (N1 IP Address field) of the ProtoCessor Ethernet port.
- If necessary, change the Netmask (N1 Netmask field).
- If necessary, change the IP Gateway (Default Gateway field).

NOTE: If the ProtoCessor is connected to a managed switch/router, the IP Gateway of the ProtoCessor should be set to the IP Address of that managed switch/router.

- Click the “System Restart” button at the bottom of the page to apply changes and restart the ProtoCessor.
- Unplug Ethernet cable from PC and connect it to the network switch or router.
- Record the IP Address assigned to the ProtoCessor for future reference.**

6 HOW TO START THE INSTALLATION OVER: CLEARING PROFILES

- After setting a local PC to the same subnet as the ProtoCessor (**Section 5.1**), open a web browser on the PC and enter the IP Address of the ProtoCessor; the default address is 192.168.1.24.
- If the IP Address of the ProtoCessor has been changed by previous configuration, the assigned IP Address must be gathered from the network administrator.
- Login to the Web App.
- Click to the Configuration tab and then click the Profiles Configuration button to open the Web Configurator page.
- At the bottom-left of the page, click the “Clear Profiles and Restart” button.
- Once restart is complete, all past profiles discovered and/or added via Web Configurator are deleted. The unit can now be reinstalled.

7 BACNET EXPLORER NG

A typical working example of a BACnet Explorer NG on a BACnet Network:

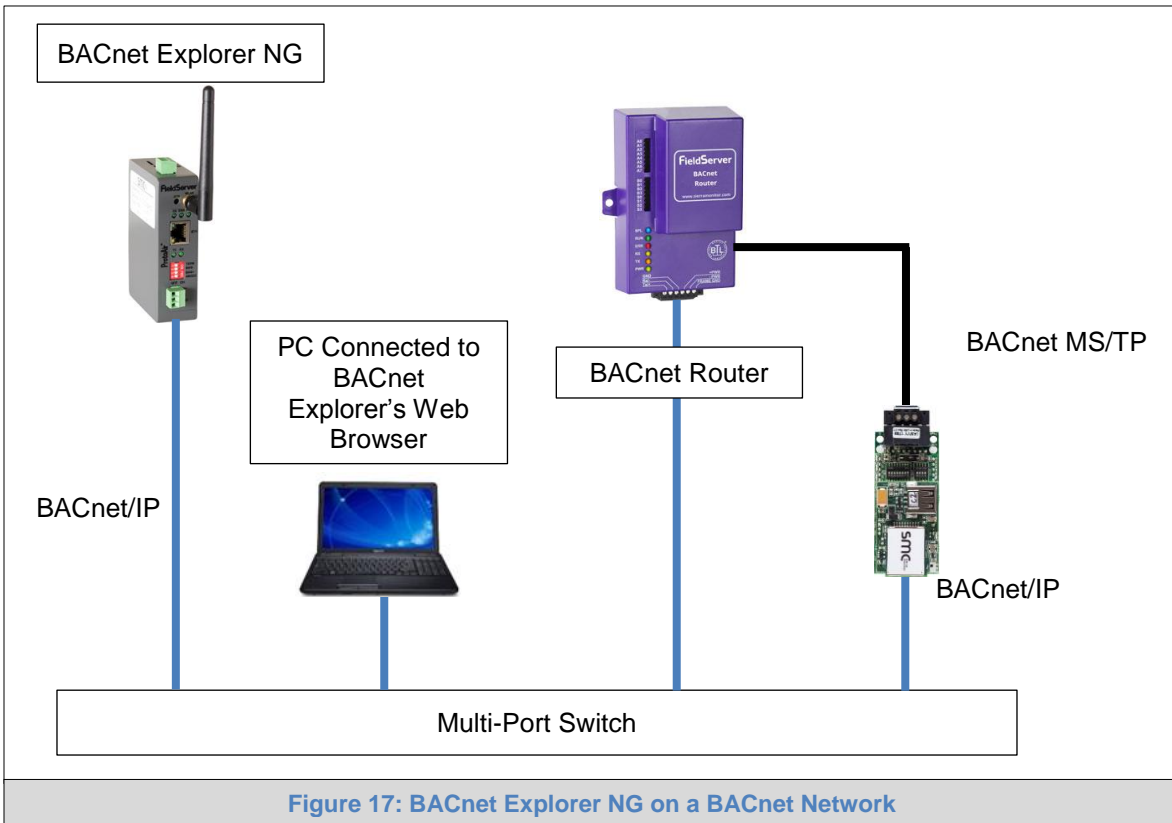

Figure 17: BACnet Explorer NG on a BACnet Network

For additional details related to the BACnet Explorer NG, go to the Sierra Monitor website's [Resource Center](#) and download the BACnet Explorer NG Start-up Guide.

For purchasing information, look up the [BACnet Explorer NG page](#) on the Sierra Monitor website and click on the "BUY NOW" tab.

Appendix A. Troubleshooting

Appendix A.1. Lost or Incorrect IP Address

- Ensure that FieldServer Toolbox is loaded onto the local PC. Otherwise, download the FieldServer-Toolbox.zip via the Sierra Monitor Resource Center [Software Downloads](#).
- Extract the executable file and complete the installation.

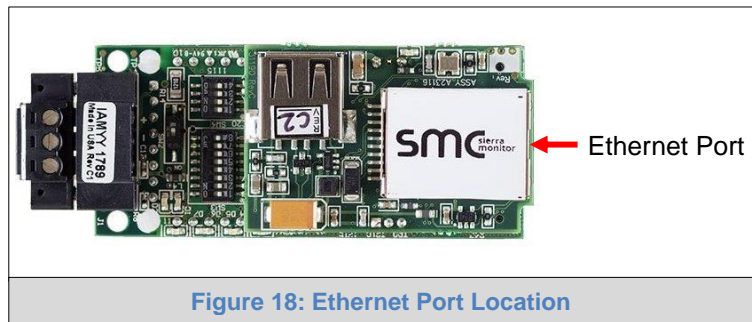
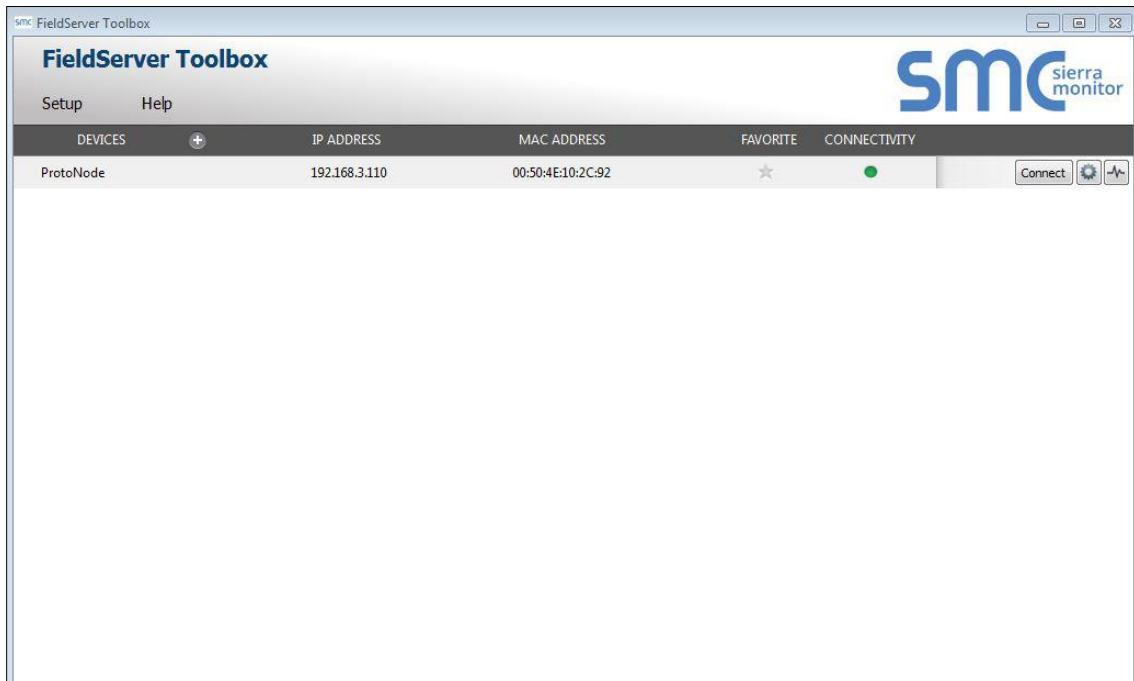



Figure 18: Ethernet Port Location

- Connect a standard CAT5 Ethernet cable between the user's PC and ProtoCessor.
- Double click on the FS Toolbox Utility and click Discover Now on the splash page.
- Check for the IP Address of the desired gateway.



- If correcting the IP Address of the gateway: click the settings icon  on the same row as the gateway, then click Network Settings, change the IP Address and click Update IP Settings to save.

Appendix A.2. Viewing Diagnostic Information

- Type the IP Address of the ProtoCessor into the web browser or use the FieldServer Toolbox to connect to the ProtoCessor.
- Click on Diagnostics and Debugging Button, then click on view, and then on connections.
- If there are any errors showing on the Connection page, refer to [Appendix A.3](#) for the relevant wiring and settings.

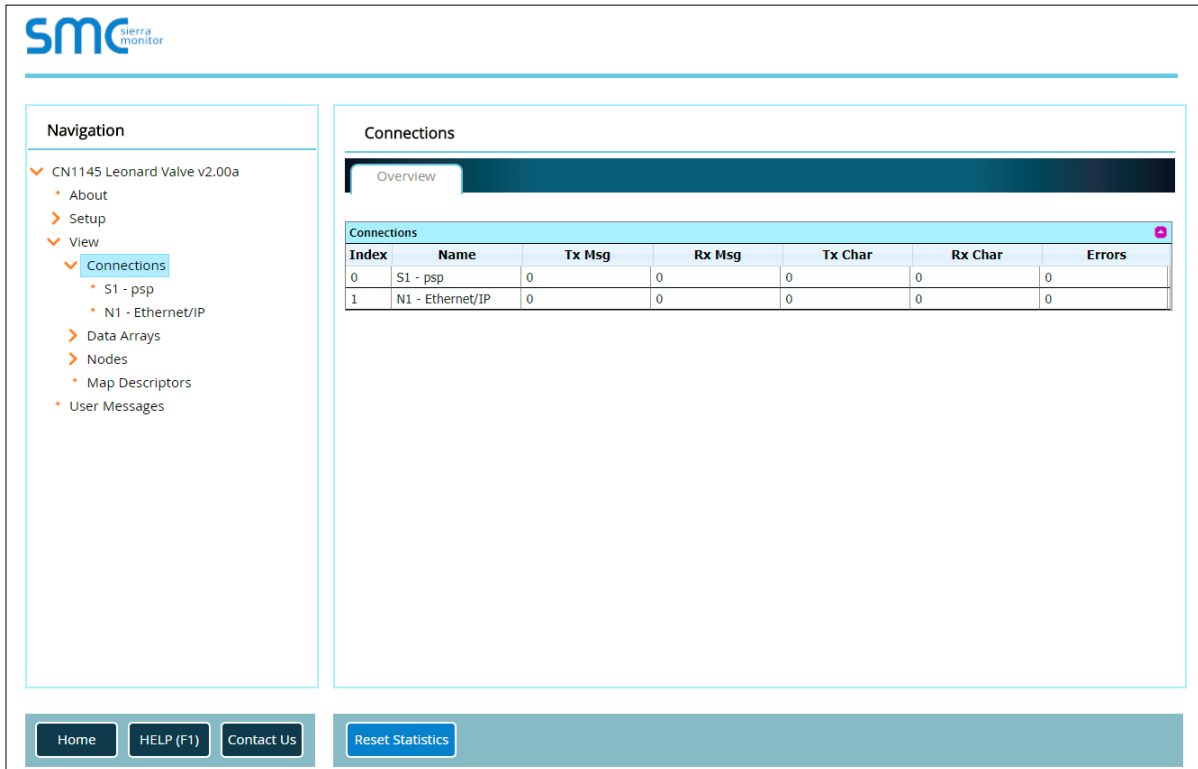

Figure 19: Error Messages Screen

Appendix A.3. Check Wiring and Settings

- No COMS on PSP side. If the Tx/Rx LEDs are not flashing rapidly then there is a COM issue. To fix, check the following:
 - Visual observations of LEDs on ProtoCessor ([Appendix A.4](#))
 - Check baud rate, parity, data bits, stop bits
 - Check device address
 - Verify device is connected to the same subnet as the ProtoCessor
 - Verify the Modbus device was discovered in Web Configurator ([Section 5.2](#))
- Field COM problems:
 - If Ethernet protocols are used, observe Ethernet LEDs on the ProtoCessor ([Appendix A.4](#))
 - Check dipswitch settings (using correct baud rate and device instance)
 - Verify IP Address setting
 - Verify wiring

NOTE: If the problem persists, a Diagnostic Capture needs to be taken and sent to support. ([Appendix A.5](#))

Appendix A.4. LED Diagnostics for Communications Between ProtoCessor and Device

Please see the diagram below for ProtoCessor FPC-ED2 LED Locations.

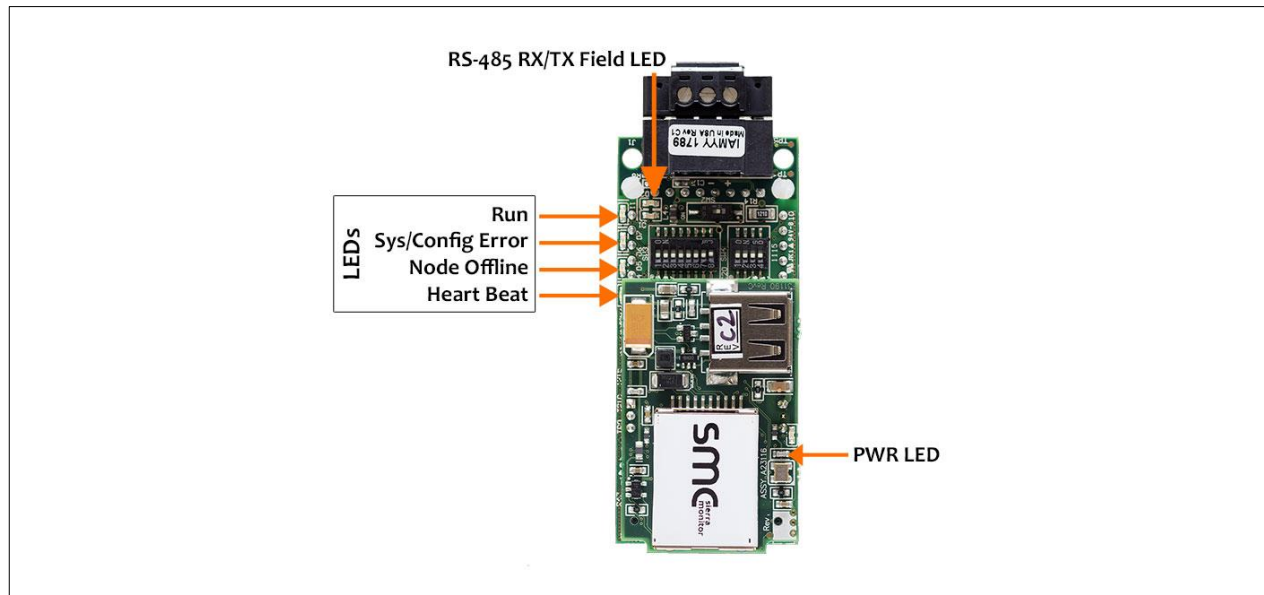

Tag	Description
Run	The Run LED will start flashing 20 seconds after power indicating normal operation. The Heart Beat LED has the same functionality but flashes more rapidly.
Sys/Config Error	The Sys/Config Error LED will go on solid 15 seconds after power up. It will turn off after 5 seconds. A steady red light will indicate there is a system error on ProtoCessor. If this occurs, immediately report the related "system error" shown in the error screen of the GUI interface to Sierra Monitor Corporation for evaluation.
Node Offline	The Node Offline LED will turn on and stay solid if there is no communication with the device.
RX	The RX LED will flash when a message is received on the field port.
TX	The TX LED will flash when a message is sent on the field port.
PWR	This is the power light and should show steady green when ProtoCessor is powered.

Figure 20: Diagnostic LEDs

Appendix A.5. Take Diagnostic Capture with the FieldServer Toolbox

- Once the Diagnostic Capture is complete, email it to info@leonardvalve.com. The Diagnostic Capture will accelerate diagnosis of the problem.
- Ensure that FieldServer Toolbox is loaded onto the local PC. Otherwise, download the FieldServer-Toolbox.zip via the Sierra Monitor Resource Center [Software Downloads](#).
- Extract the executable file and complete the installation.

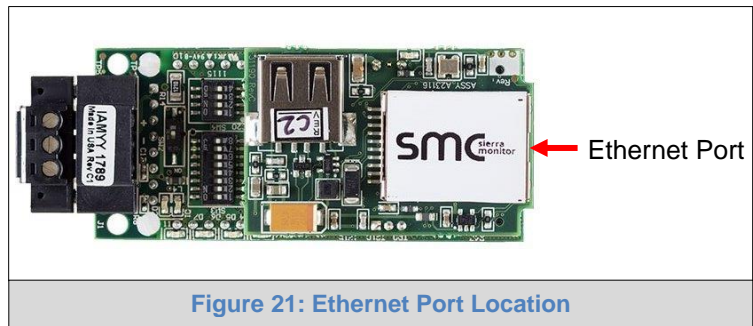

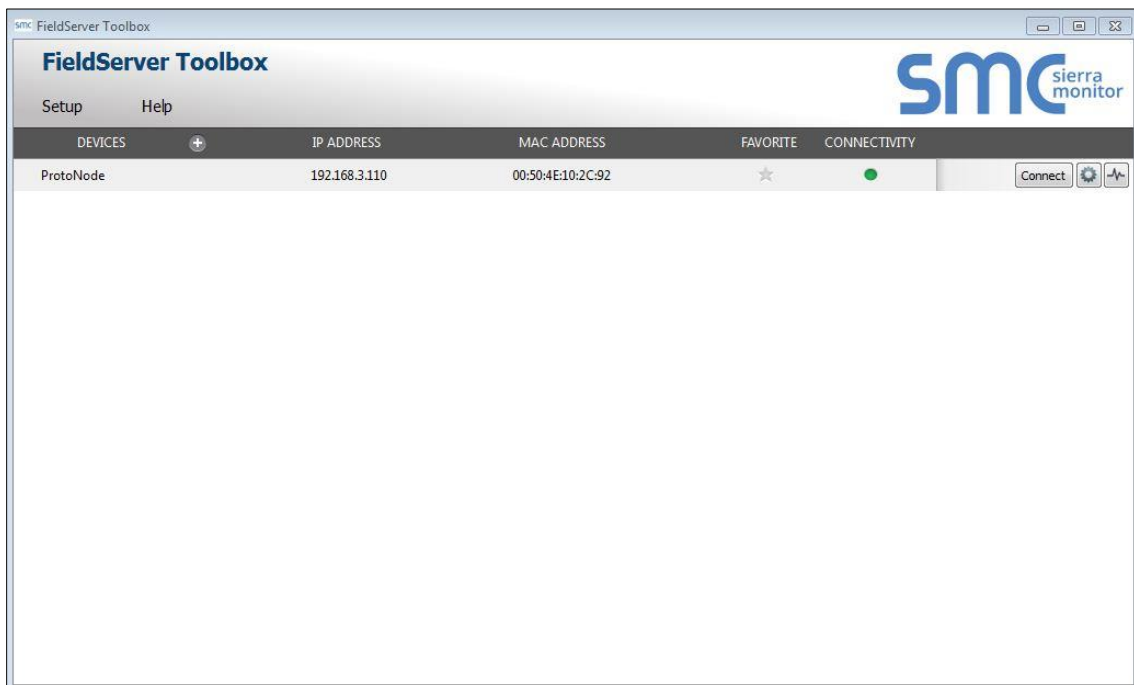

Figure 21: Ethernet Port Location

- Connect a standard CAT5 Ethernet cable between the PC and ProtoCessor.
- Double click on the FS Toolbox Utility.
- **Step 1:** Take a Log
 - Click on the diagnose icon  of the desired device



- o Ensure "Full Diagnostic" is selected (this is the default)



NOTE: If desired, the default capture period can be changed.

- o Click on "Start Diagnostic"

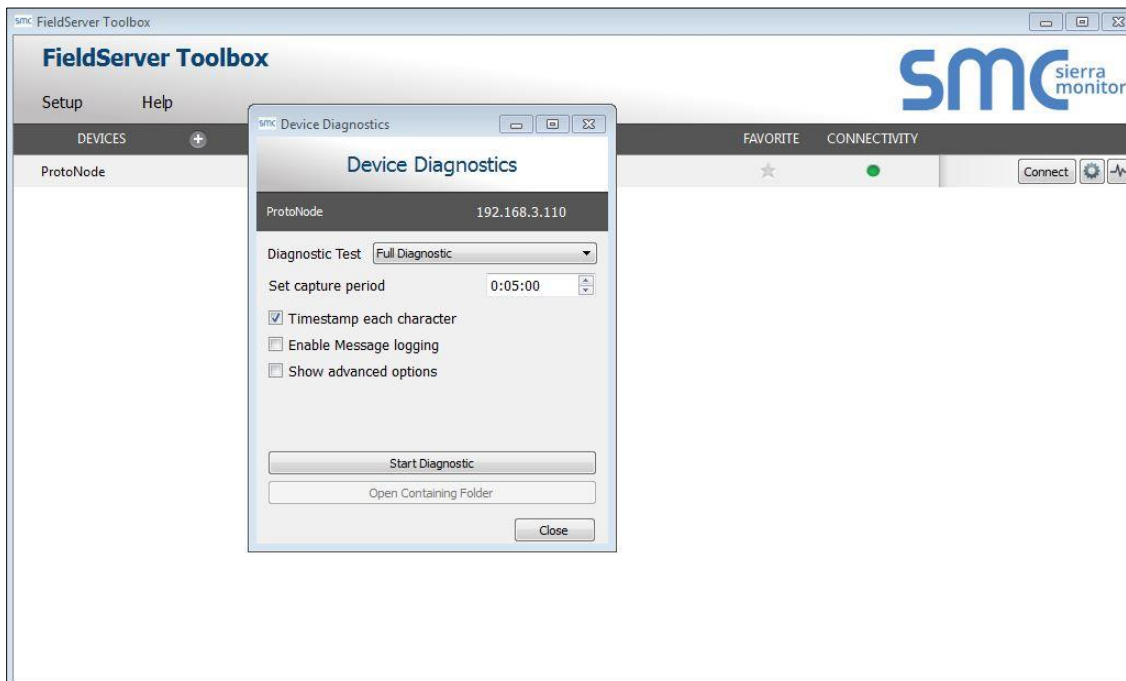

- o When the capture period is finished, the "Diagnostic Test Complete" window will appear

- **Step 2: Send Log**
 - Once the diagnostic test is complete, a .zip file is saved on the PC

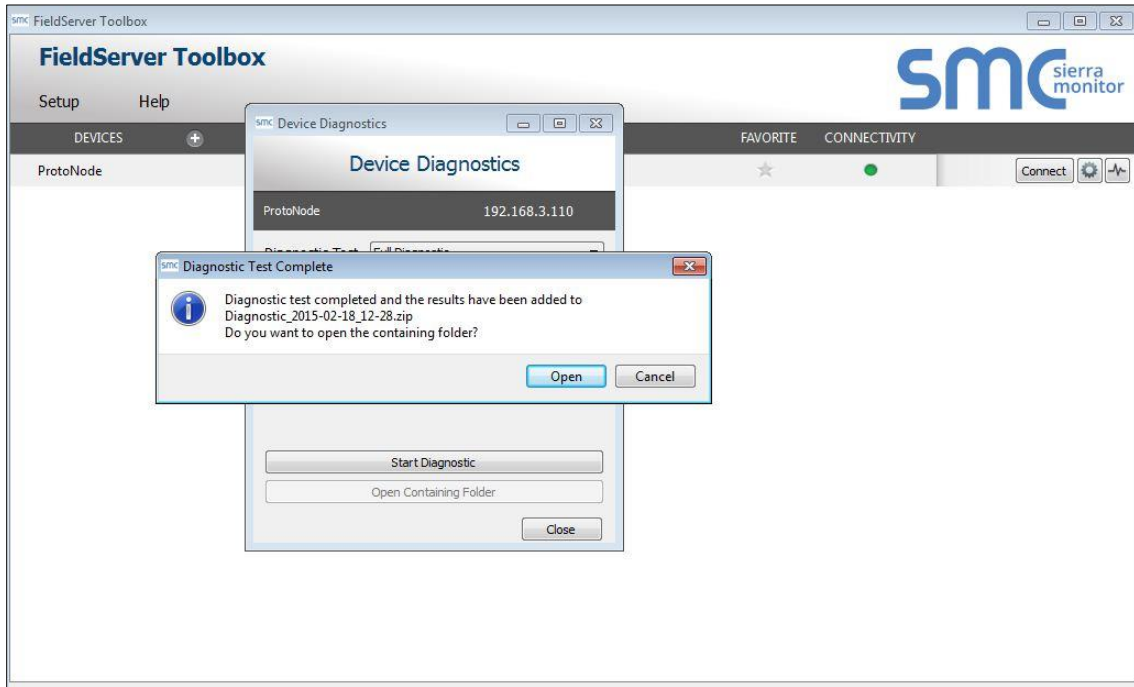

- Choose "Open" to launch explorer and have it point directly at the correct folder
- Send the Diagnostic zip file to info@leonardvalve.com

 Diagnostic_2014-07-17_20-15.zip	2014/07/17 20:16	zip Archive	676 KB
---	------------------	-------------	--------

Appendix A.6. Update Firmware

To load a new version of the firmware, follow these instructions:

1. Extract and save the new file onto the local PC.
2. Open a web browser and type the IP Address of the FieldServer in the address bar.
 - o Default IP Address is 192.168.1.24
 - o Use the FS Toolbox utility if the IP Address is unknown ([Appendix A.1](#))
3. Click on the “Diagnostics & Debugging” button.
4. In the Navigation Tree on the left hand side, do the following:
 - a. Click on “Setup”
 - b. Click on “File Transfer”
 - c. Click on the “Firmware” tab
5. In the Firmware tab, click on “Choose Files” and select the firmware file extracted in step 1.
6. Click on the orange “Submit” button.
7. When the download is complete, click on the “System Restart” button.

Appendix A.7. BACnet: Setting Network_Number for more than one ProtoCessor on Subnet

For both BACnet MS/TP and BACnet/IP, if more than one ProtoCessor is connected to the same subnet, they must be assigned unique Network_Number values.

On the main Web Configuration screen, update the Network Number with the “network_nr” field and click submit. The default value is 50.

network_nr	<p>BACnet Network Number This sets the BACnet network number of the Gateway. <i>(1 - 65535)</i></p>	50	Submit
------------	--	----	--------

Figure 22: Web Configurator – Network Number Field

Appendix A.8. Securing ProtoCessor with Passwords

Access to the ProtoCessor can be restricted by enabling a password. There are 2 access levels defined by 2 account names: Admin and User.

- The Admin account has unrestricted access to the ProtoCessor.
- The User account can view any ProtoCessor information, but cannot make any changes or restart the ProtoCessor.

The password needs to be a minimum of eight characters and **is case sensitive**.

If the password is lost, click cancel on the password authentication popup window, and email the password recovery token to info@leonardvalve.com to receive a temporary password from the support team. Access the ProtoCessor to set a new password.

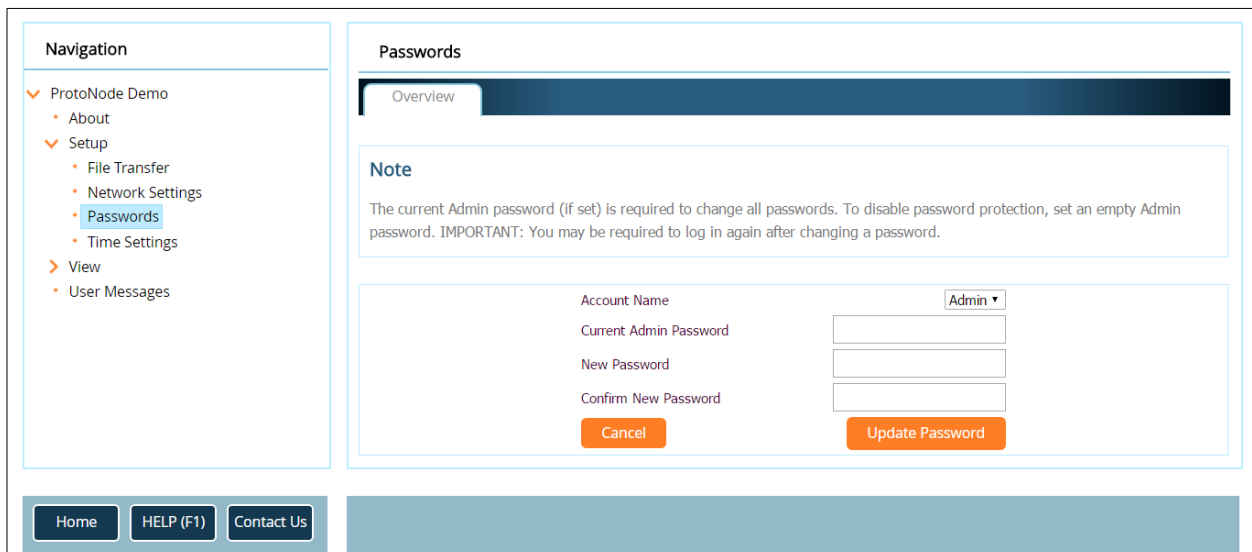

Figure 23: FS-GUI Passwords Page



Figure 24: Password Recovery Page

Appendix B. Vendor Information – Leonard Valve

NOTE: All Modbus TCP/IP registers are the same as the Modbus RTU registers for the serial device. If this point list is needed, contact the OEM. The Modbus TCP/IP node address of the device is also the same as the Modbus RTU node address.

Appendix B.1. Valve Modbus RTU Mappings to BACnet, Metasys N2 and EtherNet/IP

Point Name	BACnet Object Type	BACnet Object ID	N2 Data Type	N2 Address	Modbus Register	EIP Tag Name
TempOut	AI	1	AI	1	30001	AI_0X[0]
TempHotIn	AI	2	AI	2	30002	AI_0X[1]
TempColdIn	AI	3	AI	3	30003	AI_0X[2]
TempReturnIn	AI	4	AI	4	30004	AI_0X[3]
PressHotIn	AI	5	AI	5	30005	AI_0X[4]
PressColdIn	AI	6	AI	6	30006	AI_0X[5]
AuxTemp5	AI	7	AI	7	30007	AI_0X[6]
AuxTemp6	AI	8	AI	8	30008	AI_0X[7]
AuxTemp7	AI	9	AI	9	30009	AI_0X[8]
AuxTemp8	AI	10	AI	10	30010	AI_0X[9]
AuxPress3	AI	11	AI	11	30011	AI_0X[10]
AuxFlow1	AI	12	AI	12	30012	AI_0X[11]
AuxFlow2	AI	13	AI	13	30013	AI_0X[12]
SweepRange	AI	14	AI	14	30014	AI_0X[13]
LastSweepRange	AI	15	AI	15	30015	AI_0X[14]
Version	AI	16	AI	16	30016	AI_0X[15]
SerialNumber	AI	17	AI	17	30017	AI_0X[16]
SetPoint	AV	18	AO	18	40001	AV_0X[0]
MinOutTemp	AV	19	AO	19	40002	AV_0X[1]
MaxOutTemp	AV	20	AO	20	40003	AV_0X[2]
Kp	AV	21	AO	21	40004	AV_0X[3]
Ki	AV	22	AO	22	40005	AV_0X[4]
Kd	AV	23	AO	23	40006	AV_0X[5]
ErrCode	AV	24	AO	24	40007	AV_0X[6]
DisinfectTime	AV	25	AO	25	40008	AV_0X[7]
MinAuxTemp5	AV	26	AO	26	40009	AV_0X[8]
MaxAuxTemp5	AV	27	AO	27	40010	AV_0X[9]
MinAuxTemp6	AV	28	AO	28	40011	AV_0X[10]
MaxAuxTemp6	AV	29	AO	29	40012	AV_0X[11]
MinAuxTemp7	AV	30	AO	30	40013	AV_0X[12]
MaxAuxTemp7	AV	31	AO	31	40014	AV_0X[13]
MinAuxTemp8	AV	32	AO	32	40015	AV_0X[14]
MaxAuxTemp8	AV	33	AO	33	40016	AV_0X[15]
ErrorTTL	AV	34	AO	34	40017	AV_0X[16]
ErrorTTML	AV	35	AO	35	40018	AV_0X[17]
Scale	BV	36	DO	36	1	BV_0X[0]
Alarm	BV	37	DO	37	2	BV_0X[1]
ErrorState	BV	38	DO	38	3	BV_0X[2]
ValveSweep	BV	39	DO	39	4	BV_0X[3]
Disinfect	BV	40	DO	40	5	BV_0X[4]
Commision	BV	41	DO	41	6	BV_0X[5]

Appendix C. Reference

Appendix C.1. Specifications



ProtoCessor FPC-ED2	
Electrical Connections	One 3-pin Phoenix connector with RS-485 port (+ / - / gnd) One Ethernet 10/100 BaseT port
Approvals	CE Certified; TUV approved to UL 916, EN 60950-1, EN 50491-3 and CSA C22-2 standards; FCC Class A Part 15; DNP 3.0 Conformance Tested; RoHS Compliant; CSA 205 Approved BTL Marked
Power Requirements	5V DC
Physical Dimensions	6.9 x 3.0 x 2.0 cm (2.7 x 1.2 x 0.8 in.)
Weight	0.03 kg (0.07 lbs)
Operating Temperature	-40°C to 75°C (-40°F to 167°F)
Surge Suppression	EN61000-4-2 ESD EN61000-4-3 EMC EN61000-4-4 EFT
Humidity	5 - 90% RH (non-condensing)
(Specifications subject to change without notice)	
Figure 25: Specifications	

Appendix C.1.1. Compliance with UL Regulations

For UL compliance, the following instructions must be met when operating ProtoCessor.

- The units shall be powered by listed LPS or Class 2 power supply suited to the expected operating temperature range.
- The interconnecting power connector and power cable shall:
 - Comply with local electrical code
 - Be suited to the expected operating temperature range
 - Meet the current and voltage rating for ProtoCessor
- Furthermore, the interconnecting power cable shall:
 - Be of length not exceeding 3.05m (118.3")
 - Be constructed of materials rated VW-1, FT-1 or better
- If the unit is to be installed in an operating environment with a temperature above 65 °C, it should be installed in a Restricted Access Area requiring a key or a special tool to gain access.
- This device must not be connected to a LAN segment with outdoor wiring.

Appendix D. Limited 2 Year Warranty

Sierra Monitor Corporation warrants its products to be free from defects in workmanship or material under normal use and service for two years after date of shipment. Sierra Monitor Corporation will repair or replace any equipment found to be defective during the warranty period. Final determination of the nature and responsibility for defective or damaged equipment will be made by Sierra Monitor Corporation personnel.

All warranties hereunder are contingent upon proper use in the application for which the product was intended and do not cover products which have been modified or repaired without Sierra Monitor Corporation's approval or which have been subjected to accident, improper maintenance, installation or application, or on which original identification marks have been removed or altered. This Limited Warranty also will not apply to interconnecting cables or wires, consumables or to any damage resulting from battery leakage.

In all cases Sierra Monitor Corporation's responsibility and liability under this warranty shall be limited to the cost of the equipment. The purchaser must obtain shipping instructions for the prepaid return of any item under this warranty provision and compliance with such instruction shall be a condition of this warranty.

Except for the express warranty stated above, Sierra Monitor Corporation disclaims all warranties with regard to the products sold hereunder including all implied warranties of merchantability and fitness and the express warranties stated herein are in lieu of all obligations or liabilities on the part of Sierra Monitor Corporation for damages including, but not limited to, consequential damages arising out of/or in connection with the use or performance of the product.